

VIBCO VANE REPLACEMENT INSTRUCTIONS

SVR High Frequency Units



WARNING: Failure to read and follow these installation instructions and safety precautions could result in personal injury, equipment damage, shortened service life or unsatisfactory equipment performance. All information in this document is vital to the proper installation and operation of the equipment. It is important that all personnel who will be coming in contact with this product thoroughly read and understand this manual.

1 THANK YOU FOR CHOOSING VIBCO VIBRATORS



Remember, **VIBCO Technicians** are available **24/7** at our toll free number **800-633-0032**

2 FILING VANE SLOT

Due to constant hammering of rotor against the shaft vane slot inside shaft may shrink slightly from sand, cement or other debris.

Remove vane from slot, find and file down sharp edges. See picture for reference.

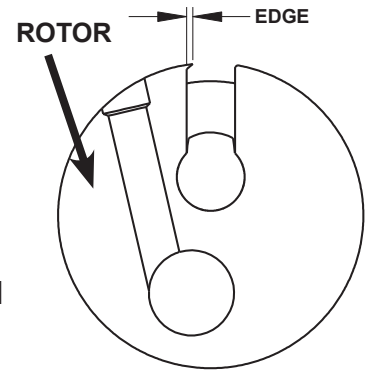

3 SIZING NEW VANE

New vanes come from the factory a little big to ensure the perfect fit. Be sure to check vane in slot before sanding.

Use a fine emery cloth to sand side of vane to a slight push fit. Length of vane is OK. **DO NOT** sand these sides.

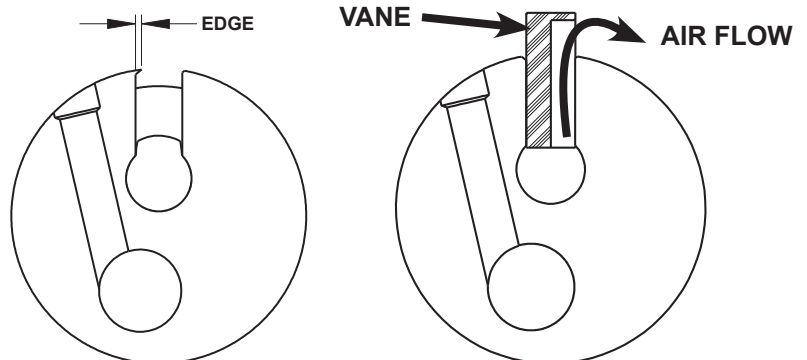

4 INSTALLING NEW VANE

Be sure vane is installed properly. Vane slots should be positioned opposite of the exhaust holes.

Unit will not run if inserted incorrectly. If vane is too tight in shaft unit will run slow. Remove shaft, check fit of vane and sand accordingly.

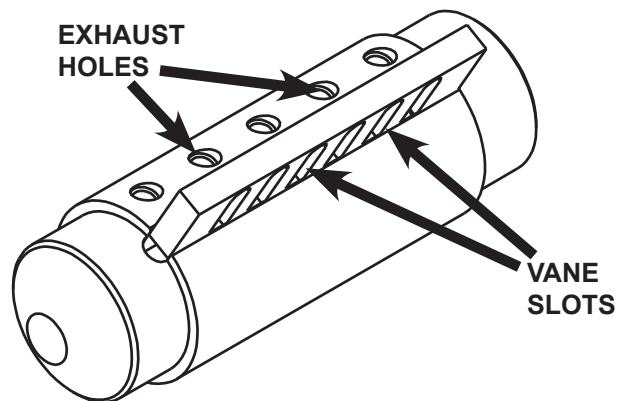

We're The Vibrator Guys.™

Corporate HQ & Factory:
75 Stilson Road Wyoming, RI
02898
Phone: 800 633-0032
(401) 539-2392
Fax: (401) 539-2584
E-mail: vibrators@vibco.com
Website: www.vibco.com

Canada:
2215 Dunwin Drive
Mississauga, ONT L5L 1X1
Phone: 800 465-9709
(905) 828-4191
Fax: (905) 828-5015